

SECTION A-A  
SCALE 1:5

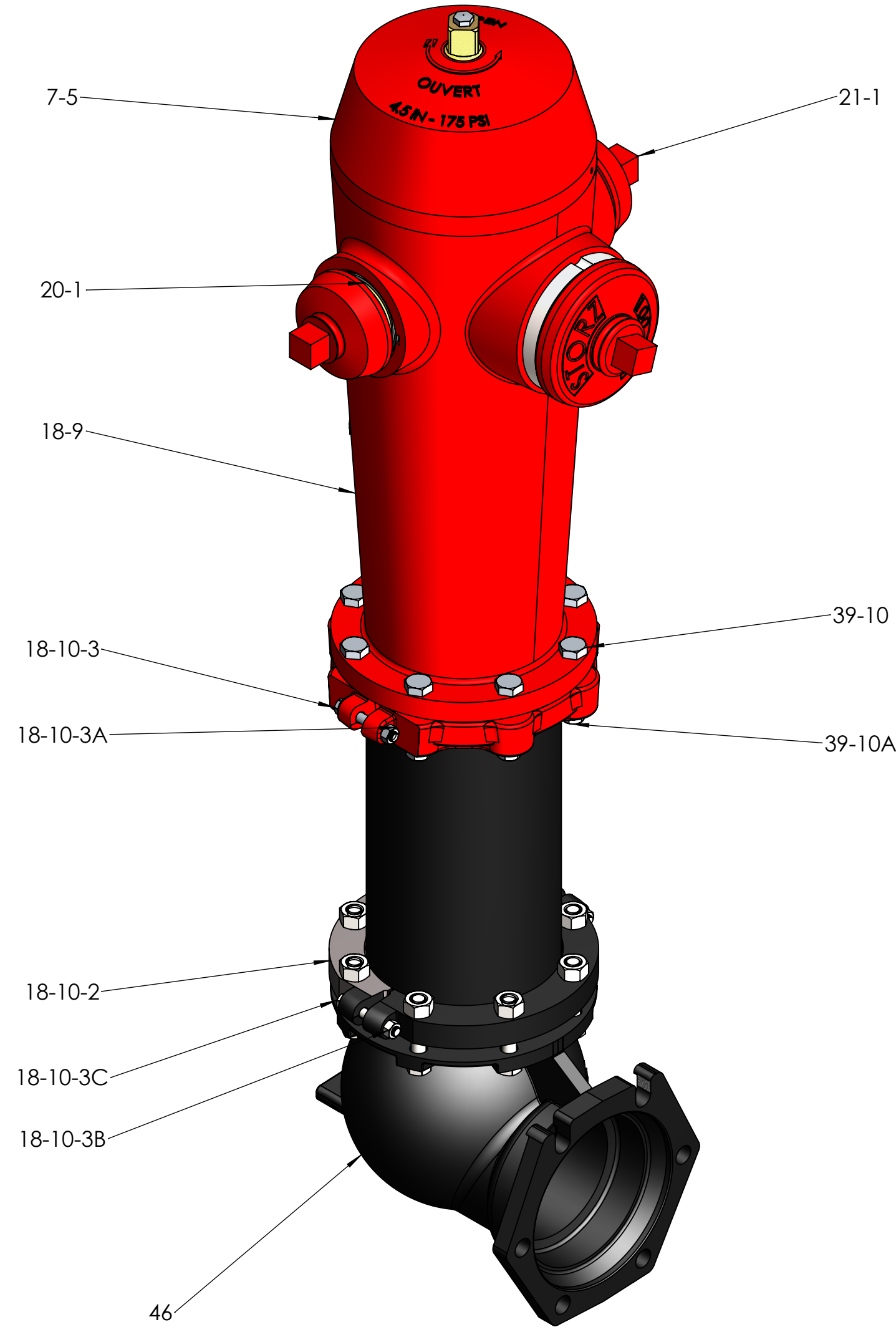
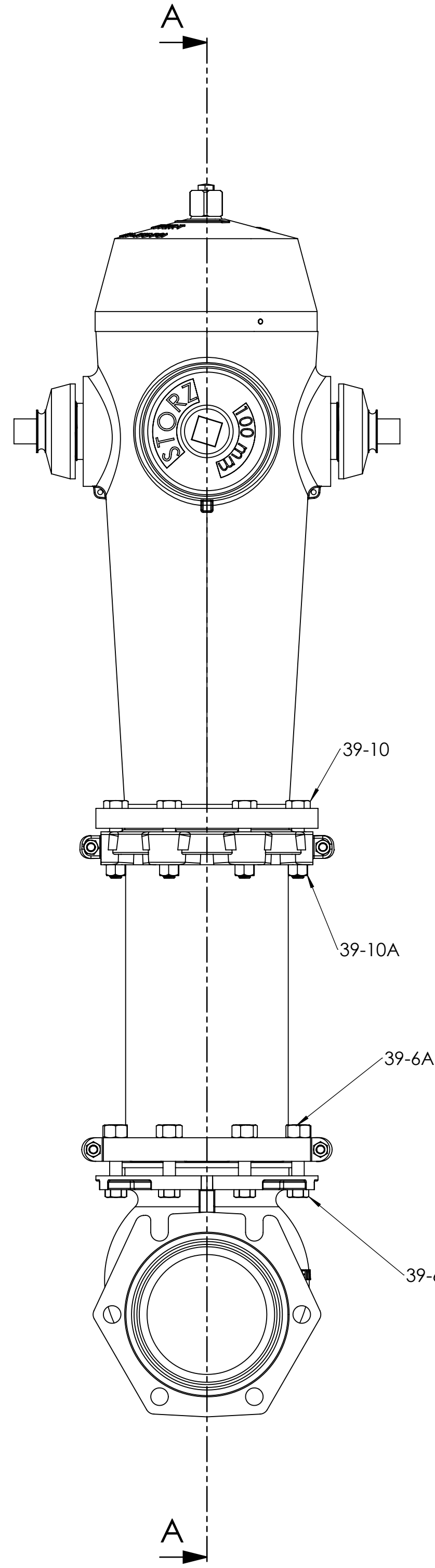

CATALOG#	DESCRIPTION	Material	QTY.
1	OPERATING NUT	MANGANESE BRONZE	1
2-1	BONNET AND HOUSING COVER O-RING	RUBBER	2
2-2	STEM SEAL O-RING (#214)	RUBBER	2
3	LUBRICATING SCREW	STAINLESS STEEL	1
4-1	CV HYDRANT THRUST BEARING	PLASTIC	1
7-5	CV HYDRANT BONNET	CAST IRON	1
9-1	BEARING HOUSING COVER	CAST IRON	1
14	CV HYDRANT BEARING HOUSING GASKET	FIBER BOARD	1
15-2	CV HYDRANT BEARING HOUSING	CAST IRON	1
15-2A	E/M BEARING HOUSING SLEEVE	PLASTIC	1
15-2B	BEARING HOUSING O-RING (#129)	RUBBER	2
16-2	BEARING HOUSING SCREW CAP	STEEL	4
16-3	BEARING HOUSING SCREW CAP (LONG)	STEEL	4
	BEARING HOUSING SCREW CAP (SHORT)	STEEL	2
18-9	CV CENTURY UPPER BARREL 2 HOSE 1 PUMPER	CAST IRON	1
18-10-1	C.V. LOWER BARREL	DUCTILE IRON PIPE	1
18-10-2	CV DUCTILE IRON HYDRANT BARREL FLANGE	DUCTILE IRON	1
18-10-2T	CV SPLIT TRAFFIC FLANGE	CAST IRON	1
18-10-3	FLANGE SIDE BOLT, GROUND LINE	STAINLESS STEEL	2
18-10-3A	FLANGE SIDE NUT, GROUND LINE	STAINLESS STEEL	2
18-10-3B	FLANGE SIDE NUT, BELOW GROUND	STAINLESS STEEL	2
18-10-3C	FLANGE SIDE BOLT, BELOW GROUND	STAINLESS STEEL	2
20-1	HOSE NOZZLE	BISMUTH BRASS	2
20-2	HOSE NOZZLE RETAINING RING	Cast Carbon Steel	2
20-3	HOSE NOZZLE GASKET	RUBBER	2
21-1	HOSE NOZZLE CAP	CAST IRON	2
22	HOSE NOZZLE CAP GASKET	RUBBER	2
25-3	PUMPER NOZZLE	STAINLESS STEEL	1
25-4	PUMPER NOZZLE RETAINER	BISMUTH BRASS	1
25-5	PUMPER NOZZLE O-RING (#352)	RUBBER	1
26-1	PUMPER NOZZLE CAP	CAST IRON	1
27	PUMPER NOZZLE CAP GASKET	RUBBER	1
30-5-1	CV HYDRANT UPPER ROD - OPEN LEFT	HRS	1
30-6	LOWER ROD, CV HYDRANT	HRS	1
30-51 T	CV FIRE HYDRANT BREAKABLE ROD COUPLING	CAST IRON	1
30-51-1	CV HYDRANT ROD GUIDE	DUCTILE IRON	1
30-51-1A	ROD GUIDE SET SCREW	STEEL	1
30-51-2A	COUPLING COTTER PIN	STAINLESS STEEL	2
30-51-2T	COUPLING CLEVIS PIN	COLD ROLLED STEEL	2
31	DRIP LEVER	DUCTILE IRON	1
32	DRIP LEVER COTTER PIN	CARTRIGE BRASS	3
33-1	DRIP LEVER WASHER	PLASTIC	3
33-1A	DRIP WASHER RETAINER/HEX NUT	BRASS	3
33-1B	HYDRANT SEAT DRAIN TUBE	STAINLESS STEEL	3
35	CV Ø4.5" HYDRANT SEAT	BISMUTH BRASS	1
36	CV HYDRANT SEAT GASKET 4.5"	RUBBER	1
37	CV Ø4.50" DRAIN RING	BISMUTH BRASS	1
38	BARREL AND BASE GASKET	RUBBER	3
39-6	CV HYDRANT BASE FLANGE BOLT	STAINLESS STEEL	8
39-6A	BASE FLANGE NUT	STAINLESS STEEL	8
39-10	GROUND FLANGE BOLT	CARBON STEEL	8
39-10A	GROUND FLANGE NUT	STEEL	8
40-2	VALVE BALL TOP, Ø4½ MAIN VALVE, CV HYDRANT	CAST IRON	1
41	CV HYDRANT HYDRANT VALVE	RUBBER	1
42-2	VALVE BALL BOTTOM, Ø4½ CV HYDRANT	CAST IRON	1
43-1	CV HYDRANT VALVE BALL TOP PLASTIC SLEEVE	PLASTIC	1
43-2	VALVE SLEEVE O-RING (#210)	RUBBER	1
44	3/4-10 HEX NUT	STAINLESS STEEL	1
44-1	3/4-10 HEX LOCK NUT	STAINLESS STEEL	1
46	BASE	DUCTILE IRON	1
47-1	COVER RESTRAINING KNURL PIN	STAINLESS STEEL	2
48	STOP PIN, TYPE E GROOVE, 3/8 X 2	STEEL	1

IN (MILLIMETER)	TOLERANCES - MACHINING	THIRD ANGLE PROJECTION
INCH	UNLESS OTHERWISE NOTED	
INITIAL RELEASE	BREAK EDGES FINISH SURFACES	PURCH. FINISH
DRFT'R JJS 3/10/14	MACH. .006/.016	MACH
CHK'R	125	REF. NO. SCALE
APP	FRACTIONS ±1/64 DECIMALS 2 PL ±.025 ANGLES 3 PL ±.010	STK. NO.
E.O. NUMBER	MAT'L VARIES	REVISION NUMBER
	DESCR: CANADA VALVECENTURY HYDRANT.	B HYD-CEN

UL / FM APPROVED  
175 PSI WORKING PRESSURE - 350 PSI TEST

DWG NO. HYD-CEN

REV.	DESCRIPTION	REF.	DATE