

**APPLICATIONS:** HbMAG Meter is an electromagnetic flow meter designed for use in the measurement of potable water in applications where a high degree of accuracy is required over a wide range of flow rates and conditions. Hotels, schools, factories, office buildings, apartment buildings, commercial properties and irrigation are all examples of installations where domestic and process water services may have widely varying flow rates and usage profiles. The Hersey HbMAG meter has advanced EMF measurement technology to provide a high degree of maintenance free accuracy over extended periods of deployment. Maximum continuous flow rates may be exceeded by as much as 50% for intermittent periods with virtually no pressure loss; permitting full pipe capacity measurement without damage to the meter.

**CONFORMANCE TO STANDARDS:** Hersey HbMAG meters have some of the widest flow ranges of any meter on the market. All Hersey HbMAG solid-state meters provide comparable performance, accuracy and pressure loss standards referenced in the latest editions of AWWA Standards C-701 for horizontal turbine meters and C-702 for compound meters. All 3" through 12" HbMAG meters are also available in an FM Approved variant for fire meter use.

**CONSTRUCTION:** The Hersey HbMAG consists of the epoxy coated outer main case; SST flow tube; EPDM liner; Hastelloy electrodes; and solid-state register. Main cases are made of epoxy coated steel with an EPDM liner. Electrodes are made from Hastelloy C 276. It is low maintenance, delivering long-term performance with minimal cost of ownership.

**REGISTER:** Permanently sealed LCD register with heat-treated glass lens to eliminate dirt, moisture infiltration and fogging. Displays volume of water measured, flow rate, reverse flow and low battery alarm. Additional communication outputs are available. All Hersey Models have electronic meter reading systems available for increased reading efficiency. (see Meter Reading Systems.)

**OPERATION:** The Hersey HbMAG is a microprocessor-based water meter with graphical display for optimum customer operation and information. The transmitter drives the magnetic field in the sensor, evaluates the flow signal from the sensor and calculates the volume of liquid passing through the meter. It delivers required information via the integrated solid-state register or communication interfaces as part of a system solution. The intelligent functionality, information and diagnostics ensure optimum meter performance and information to optimize water supply and billing. Water flows straight through an unobstructed body permitting high flow volumes with a virtually no head loss.

**MAINTENANCE:** The Hersey HbMAG is designed and manufactured to provide long service life with virtually no maintenance required.

**CONNECTIONS:** ANSI 150 standard end flanges



3" Hersey HbMAG with Integral Register

HbMAG

### Material and Specifications

MODEL	HbMAG
SIZES	3", 4", 6", 8" 10", 12
	Larger sizes are available. Call Mueller Systems customer care for options.
STANDARDS	IP68/NEMA 6P, NSF-61, Optional FM approval for fire meter use
SERVICE	Measurement of flow in BOTH forward and reverse directions
INSTALLATION	Horizontal or vertical with 5x pipe diameter of straight pipe (same size as meter)
OPERATING FLOW RANGE	See Charts on the following pages
ACCURACY	See Charts on the following pages
MAXIMUM WORKING PRESSURE	175 PSI
TEMPERATURE RANGE	33° F to 140° F water temperature
MEASURING ELEMENT	Time-varying magnetic field
SOLID STATE REGISTER	Permanently sealed IrDA: Standard integrated infrared communication interface with Encoder interface, AMR/AMI RF Modules
BATTERY LIFE	6 Years: Internal Battery Pack 10 Years: External Battery Pack
METER CONNECTIONS	ANSI class 150 standard end flanges
MATERIALS	Maincase – epoxy-coated steel Electrodes – Hastelloy C276 Liner - EPDM
OPTIONS	AMR/AMI Reading Systems

NORMAL FLOW RANGES				
Sizes"	Low Flow	Mid Flow	High Flow	Intermittent High Flow
3"	.5 GPM	2.75 GPM	550 GPM	825 GPM
4"	.75 GPM	4.5 GPM	880 GPM	1320 GPM
6"	1.5 GPM	11.25 GPM	2200 GPM	3300 GPM
8"	2 GPM	17.5 GPM	3465 GPM	5200 GPM
10"	8.75 GPM	28 GPM	5500 GPM	8250 GPM
12"	15 GPM	44 GPM	8800 GPM	13200 GPM

DIMENSIONS		
Sizes"	LENGTH	WEIGHT
3"	7.9"	34 lbs
4"	9.8"	38 lbs
6"	11.8"	63 lbs
8"	13.8"	113 lbs
10"	17.7"	160 lbs
12"	19.7"	198 lbs

METER ACCURACY RANGE	
Low Flow	+/- 5%
Normal Flow Ranges	+/- 0.4%

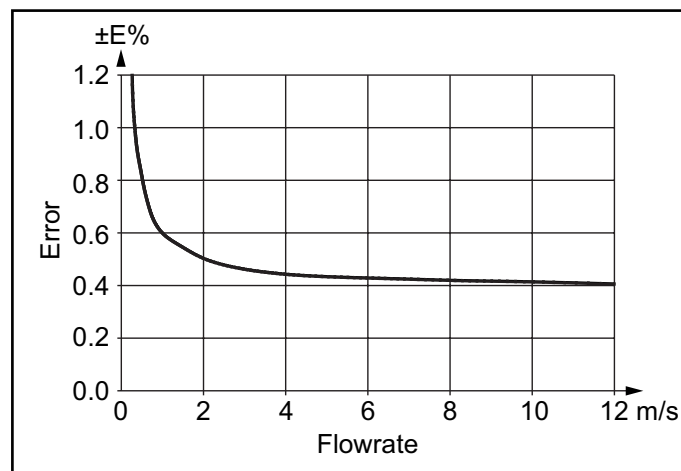

Standard calibration  
 $E = \pm 0.4\%$  of rate  $\pm 2$  mm/s

Performance curves are typical only and NOT a guarantee of performance.

### Overview



The Hersey HbMAG is a comprehensive meter which provides intelligent information and high performance measurement as well as the easy to install concept taking cost of ownership and customer service to a new level for a utility water meter.

### Benefits

#### Easy to install

- Compact or remote solutions with factory mounted cable and customer setting from factory
- IP68/NEMA 6P enclosure. Sensor can be buried
- Flexible power supply - internal or external battery pack or mains power supply with battery back-up

#### Superior measurement

- Down to 0.4% maximum uncertainty
- Bi-directional measurement

#### Long lasting performance/Low cost of Ownership

- No moving parts means less wear and tear
- 6 years maintenance-free operation in typical revenue applications
- Robust construction built for multiple applications

Intelligent information, easy to access

- Advanced information on site
- Data logger
- Advanced statistics and diagnostics
- Add-on communication modules

### Application

The Hersey HbMAG has been developed as a standalone water meter for applications within:

- Distribution networks
- Revenue and bulk metering
- Irrigation
- Fire Meter with optional FM Approval

### Design

The Hersey HbMAG is designed with a focus on minimized power consumption.

The product program consists of

- Sensor sizes from 3" to 48"
- Compact and remote installation in IP68/NEMA 6P enclosure and factory-mounted cable
- Hersey Flow Tool PC configuration softwares

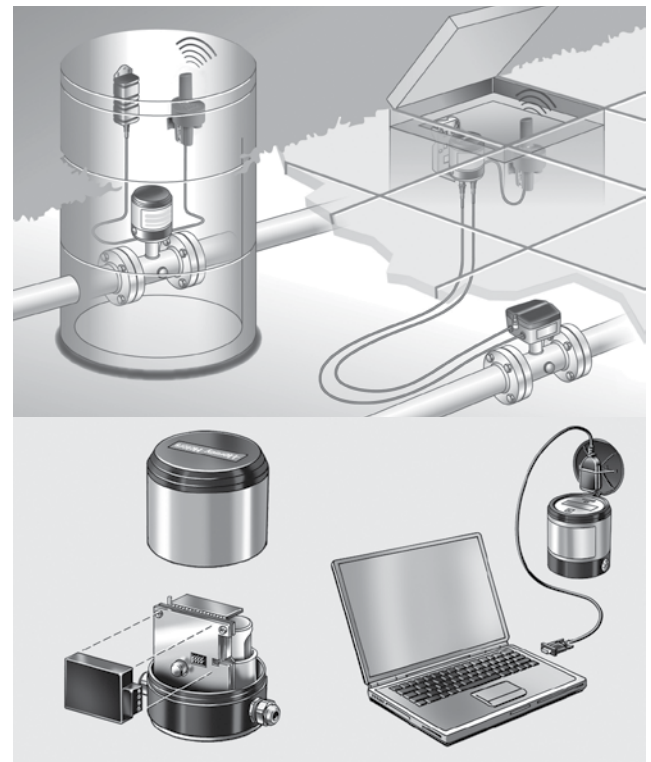

Add-on communication module (left), PC-IrDA connection (right)

■ **Function**

The Hersey HbMAG is a microprocessor-based water meter with graphical display and key for optimum customer operation and information both on site and remotely. The transmitter drives the magnetic field in the sensor, evaluates the flow signal from the sensor and calculates the volume passing through. It delivers the required information via the integrated Hersey encoder output as part of Mueller Systems AMR and AMI solutions. Its intelligent functionality, information and diagnostics ensure optimum meter performance and information to optimize water supply and billing.



The Hersey HbMAG with integral battery option provides 6 years battery operation in typical revenue applications.

FEATURES / VERSION	Hersey HbMAG
Measuring frequency in battery power mode	1/15, 1/30 or 1/60 Hz
Output HbMAG	2 FW/RV/AI/CA (max. 50 Hz pulse rate)
Communication	Encoder
Data logger	Yes

Information is accessible via the display whereas all information is accessible via the IrDA communication interface with Hersey software. Data and parameters are registered in a EEPROM. They can all be read, but changing the information demands a software password and a hardware key attached to the printed circuit board.

■ **Technical Specifications**

Meter	
Hersey HbMAG	
<b>Accuracy</b>	Standard calibration: ±0.4% of rate ±2 mm/s
<b>Media conductivity</b>	Clean water > 20 µs/cm
<b>Temperature</b>	
Ambient	-4 ... +140 °F (-20 ... +60 °C)
Media	32 ... +158 °F (0 ... +70 °C)
Storage	-22 ... +158 °F (-40 ... +70 °C)
<b>Enclosure rating</b>	IP68/NEMA 6P; Cable glands mounted requires Sylgard potting kit to remain IP68/ NEMA 6P, otherwise IP67/NEMA 4 is obtained; Factory-mounted cable provides IP68/NEMA 6P
<b>Drinking water approvals</b>	• NSF/ANSI Standard 61 (cold water) USA
<b>Sensor version</b>	3" ... 48"
<b>Measuring principle</b>	Electromagnetic induction
<b>Excitation frequency</b>	
• Battery-powered	3" - 6": 1/15 Hz 8" - 24": 1/30 Hz 28" - 48": 1/60 Hz
• Mains-powered	3" - 6": 6.25 Hz 8" - 24": 3.125 Hz
<b>Flanges</b>	
ANSI 16.5 Class 150 lb	3" - 24": 290 psi (20 bar)
AWWA C-207	28" - 48": PN 10 145 psi
Liner	EPDM
Electrode and grounding electrodes	Hastelloy C276
Grounding straps	Grounding straps are premounted from the factory on each side of the sensor

**■ Technical Specifications**
**Transmitter**

<b>Installation</b>	Compact (integral) or Remote with factory-mounted cable 33' (10 m)
<b>Enclosure</b>	Stainless steel top housing (AISI 316) and coated brass bottom. Remote wall mount bracket in stainless steel (AISI 304).
<b>Cable entries</b>	2 x M20 (one gland for one cable of size 0.02 - 0.026 ft (6 - 8 mm) is included in the standard delivery)
<b>Display</b>	Display with 8 digits for visual meter reading information. Index, menu and status symbols for dedicated information
<b>Standard Flow Units</b>	Volume in Gallon and flow rate in GPM Volume in CF and flow rate as GPM Volume in m3 and flow rate in m3/h
<b>Optional display units</b> (Available as an option in place of encoder output)	Volume: m3 x 100, l x 100, G x 100, G x 1000, MG, CF x 100, CF x 1000, AF, Al, kl Flow: m3/min, m3/d, l/s, l/min, GPS, GPH, GPD, MGD, CFS, CFM, CFH
<b>Digital output</b>	2 passive outputs (MOS), individual galvanically isolated Maximum load $\pm$ 35 V DC, 50 mA short circuit protected
Output A function	Programmable as pulse volume – forward – reverse – forward/net – reverse/net
Output B function	Programmable as pulse volume (like output A), alarm
Output	Max. pulse rate of 50 Hz , pulse width of 5, 10, 50, 100, 500 ms
<b>Communication</b>	IrDA: Standard integrated infrared communication interface with Hersey/Sensus Encoder Protocol for Hot Rod, Mi.Net, Itron AMR/AMI Systems
<b>Power supply</b>	Auto detection of power source with display symbol for operation power.
Internal battery pack	2 D-Cell 3.6 V/33 Ah
External battery pack	4 D-Cell 3.6 V/66 Ah
<b>Mains power supply</b>	<ul style="list-style-type: none"> <li>• 12 ... 24 V AC/DC (10 ... 32 V) 2 VA</li> <li>• 115 ... 230 V AC (85 ... 264 V) 2 VA</li> </ul> The power supply has 9.8 ft (3 m) power cable for external connection to mains supply (without cable plug) Both mains power supply systems are backed up by an internal D-Cell 3.6 V 16.5 Ah battery pack.
<b>Installation</b>	Integral (compact) or remote with factory mounted cable in 33' lengths with IP68/ NEMA 6P connectors. Connection is made at the transmitter bottom.
<b>Enclosure</b>	Stainless steel top housing (AISI 316) and coated brass bottom. Remote wall mount bracket in stainless steel (AISI 304).
<b>Cable entries</b>	2 x M20 (one gland for one cable of size 0.24 ... 0.31 " (6 ... 8 mm) is included in the standard delivery)

## Features

<b>Time and date</b>	<b>Real time clock</b>
<b>Totalizer</b>	2 totalizer: Forward, Reverse, Bidirectional netflow calculation and free selectable start value. 1 customer totalizer, following totalizer 1 setting and resetable via display key or software with logging of date and time
<b>Measurement</b>	
Low flow cut-off	0.05% of high flow or free adjustable
Empty pipe detection	Symbolized in display
Data logger	Logging of 26 records: selectable as daily, weekly or monthly logging
<b>Alarm</b>	Active alarm is indicated on the display
Monitoring	Total hours an alarm has been active Numbers of times the alarm has been activated First time an alarm appears Last time the alarm disappears
Fatal faults	Coil current – Fault in driving magnetic sensor field Amplifier – Fault in signal circuit Check sum – Fault in calculation or handling of data
Warning faults	Low Power – customer selectable battery alarm level or power drop out Flow overflow – Flow in sensor exceeds intermittent high flow Pulse overflow on output A and B – Selected pulse volume is too small compared to actual flow rate and max. output pulse rate. Consumption – saved data logger consumption exceeds customer selected limit on high or low consumption Empty pipe – no water in the pipe/sensor Low impedance - measured electrode impedance below customer low impedance level Flow limit – actual flow exceeds selected high flow limit
<b>Data protection</b>	All data stored in an EEPROM. Totalizers 1 and 2 are backed up every 10 min, statistics every hour and power consumption and temperature measurement every 4 hour. Password protection of all parameters and hardware protection of calibration and revenue parameters.
<b>Battery power management</b>	Optimal battery information on remaining capacity. Calculated capacity includes all consuming elements and available battery capacity is adjusted related to change in ambient temperature. Numbers of power-ups Date and time registered for first and last time power alarm.
<b>Diagnostics</b>	
Continuous self test including	Coil current to drive the magnetic field Signal input circuit Data calculation, handling and storing
Alarm statistics and logging for fault analyzing	Electrode impedance to check actual media contact Flow simulation to check pulse and communication signal chain for correct scaling Number of sensor measurements (excitations) Transmitter temperature (battery capacity calculation) Low impedance alarm for change in media Flow alarm when defined high flow is exceeded Verification mode for fast measure performance check

### Hersey HbMAG water meter uncertainty

To ensure continuous accurate measurement, flow meters must be calibrated. The calibration is conducted at flow facilities with traceable instruments referring directly to the physical unit of measurement according to the International System of Units (SI). Therefore, the calibration certificate ensures recognition of the test results worldwide, including the US (NIST traceability).

Mueller Systems can provide accredited calibration in the flow range from 0.0001 m<sup>3</sup>/h to 10 000 m<sup>3</sup>/h.

The accredited laboratories are recognized by ILAC MRA (International Laboratory Accreditation Corporation - Mutual Recognition Arrangement) ensuring international traceability and recognition of the test results worldwide.

The selected calibration determines the accuracy of the meter. A standard calibration results in max.  $\pm 0.4\%$  uncertainty. A calibration certificate is provided with every sensor and calibration data are stored in the meter unit.

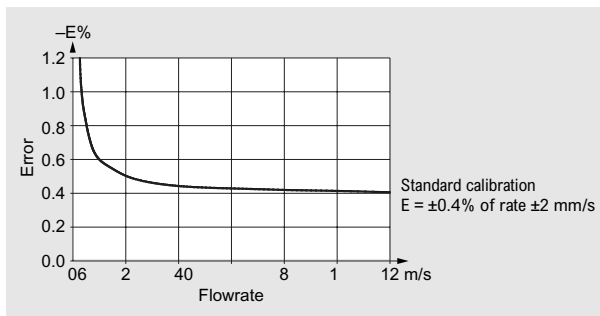

Performance curves are typical only and do not guarantee of performance.



The Label is placed on the side of the display housing. An example of the product label is shown below:

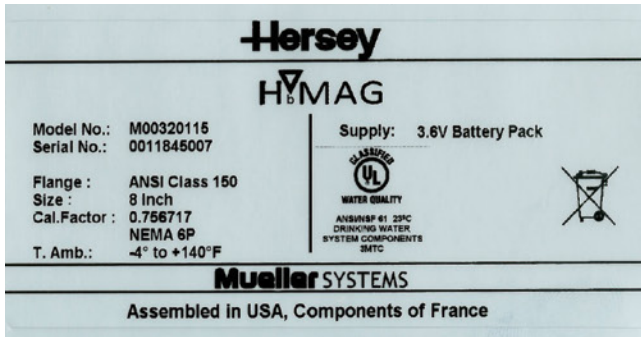

## Installation conditions

Please refer to “System information for Hersey HbMAG electromagnetic flow meters”.

Battery packs must be installed with the hanging bracket in upwards direction to reach maximum capacity.

## Bonding and grounding

The sensor body must be grounded using grounding/bonding straps and/or grounding rings to protect the flow signal against stray electrical noise and/or lightning. This ensures that the noise is carried through the sensor body and a noise-free measuring area within the sensor body.

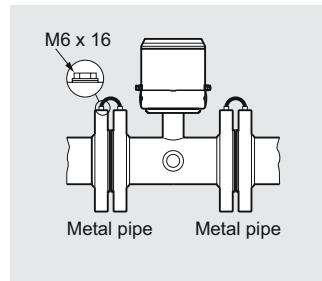

### Metal pipelines

On metal pipelines, connect the straps to both flanges.

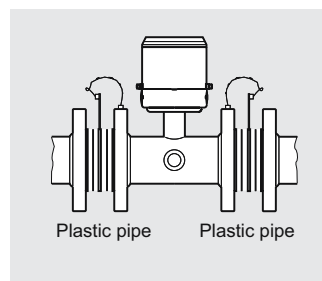

### Plastic pipelines

On plastic pipelines and lined metal pipes, optional grounding rings must be used at both ends.

Grounding rings must be ordered separately see grounding ring kit

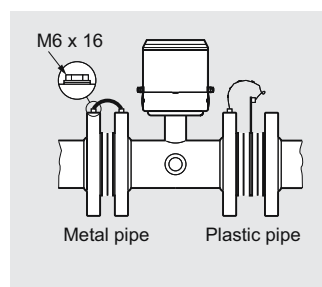

### Combination of metal and plastic pipelines

A combination of metal and plastic requires straps for metal pipeline and grounding rings for plastic pipeline.

## Output configuration HbMAG

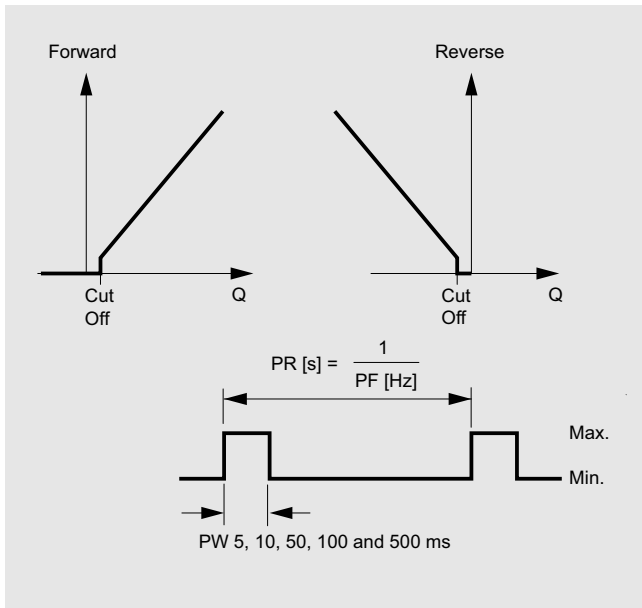

Pulse volume: Output A/B configured as volume per pulse, the output delivers a pulse when the preset volume has passed the selected direction, calculated on forward/reverse or Net forward/reverse flow. The volume per pulse is freely scalable, from 0.0001 to 10 000 meter-unit per pulse. PR = pulse rate and PF = pulse frequency.

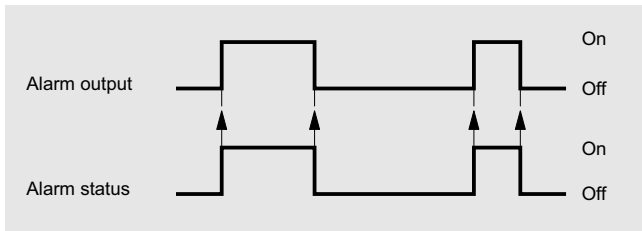

Alarm: The alarm will follow the internal alarm status.

## Battery operation time and calculation

The battery operation time depends on the connected battery pack as well as the operation condition of the meter.

HbMAG calculates the remaining capacity every 4 hours and includes all consuming elements. Calculation compensates for temperature influence on battery capacity (drawing).

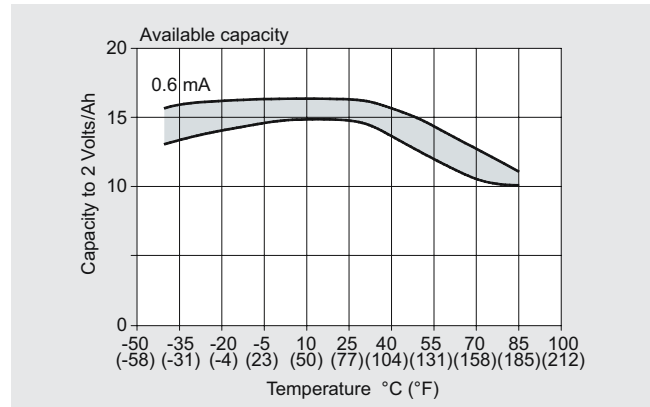

The effect from other temperatures can be seen from the figure. A variation in temperature from 15 °C to 55 °C (59 to 131 °F) reduces the capacity by 17% in the table from 15 Ah to 12.5 Ah.

At typical revenue scenario of expected battery operation time can be seen in the table.

The measurement for calculating the rest capacity of the battery life time is only completed if the system has no active fatal faults or the empty pipe is active. Maximum battery specification is 10 years operation.

### Scenario - Revenue application

Output A	Pulse rate max. 10 Hz
Output B	Alarm or call-up
Meter dialog	1 hour per month
Add-com	None
Temperature profile	<ul style="list-style-type: none"> <li>• 5% at 32 °F (0 °C)</li> <li>• 80% at 59 °F (15 °C)</li> <li>• 15% at 122 °F (50 °C)</li> </ul>

## Battery lifetime (subject to the assumptions mentioned above)

Excitation frequency (24 h operation)		1/60 Hz	1/30 Hz	1/15 Hz	1/5 Hz	1/5625 Hz	3/125 Hz	6/25 Hz
Two D-Cell battery 33 Ah Internal battery pack	3" - 8"	8 years	8 years	6 years	40 months	8 months	4 months	2 months
	10" - 24"	8 years	6 years	4 years	20 months	4 months	2 months	NA
	28" - 48"	6 years	4 years	2 years	1 year	2 months	NA	NA
Four D-Cell battery 66 Ah External battery pack	3" - 8"	N/A	10 years	10 years	80 months	16 months	8 months	4 months
	10" - 24"	N/A	10 years	10 years	40 months	8 months	4 months	NA
	28" ... 48"	10 years	8 years	4 years	2 years	4 months	NA	NA

External battery pack can be used as battery backup for mains power supply.

■ Dimensional drawings

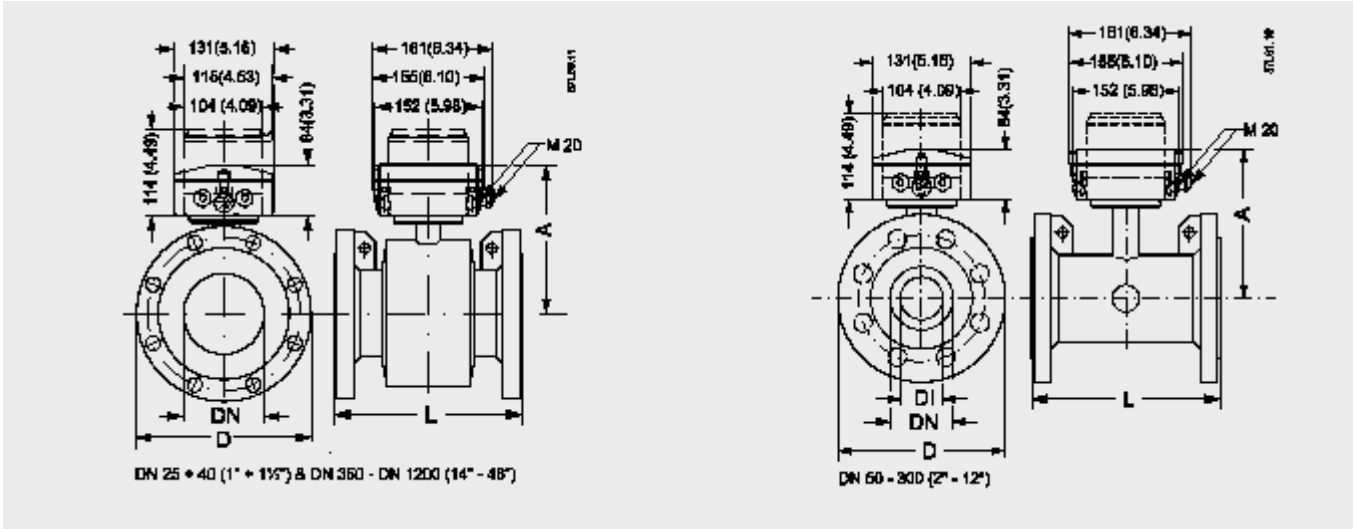

HbMAG

**Remote version**

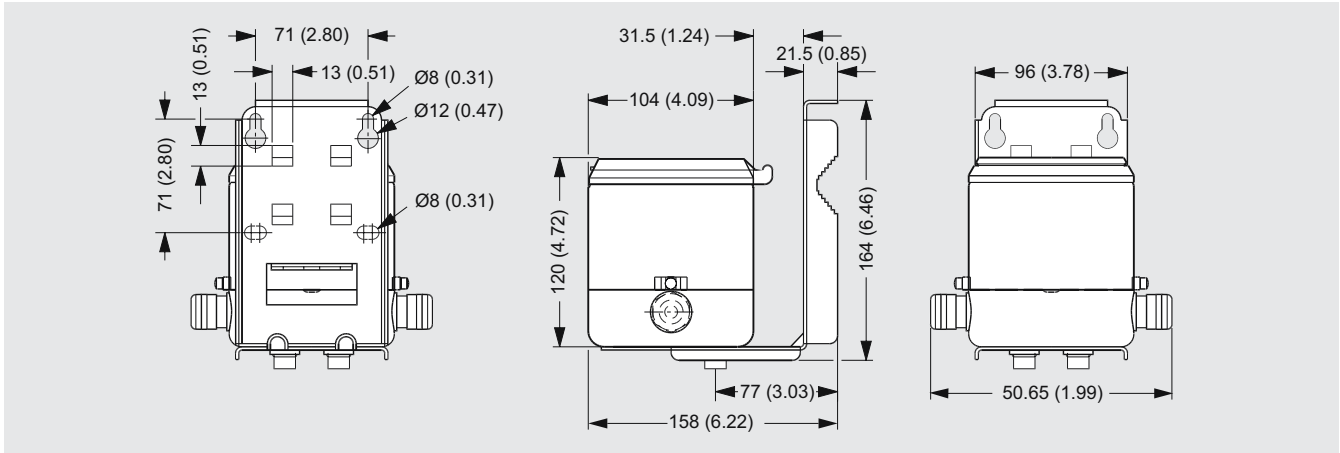

Dimensions in mm (inch), weight 3.5 kg (8 lbs)

**External battery pack**

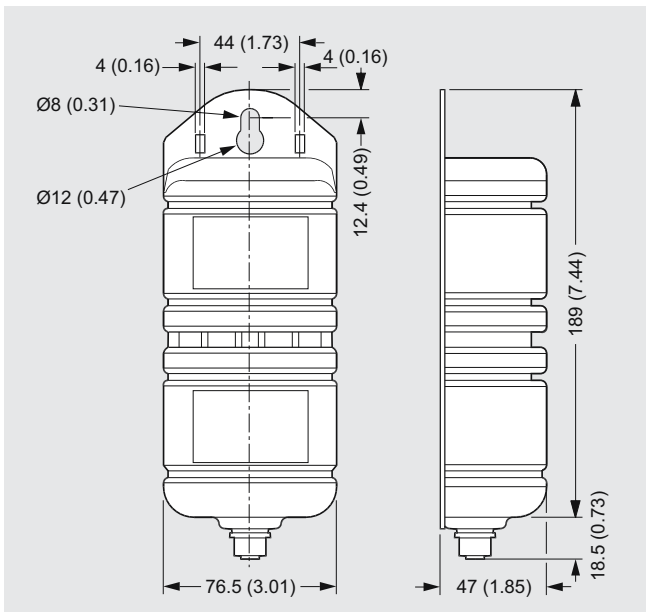

Dimensions in mm (inch), weight 2.0 kg (4.5 lbs)

Battery pack has to be mounted in upwards position to ensure maximum battery capacity.

■ Schematics

**Electrical installation and pulse output – Connection diagram**

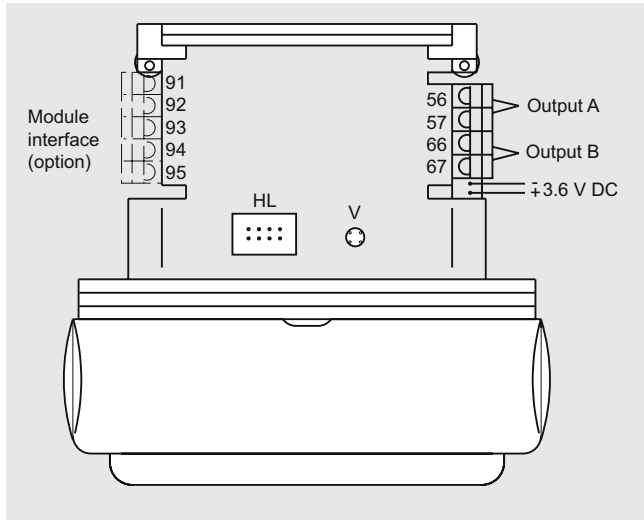

HL = Hardware lock key connection  
 V = Push button for verification mode

**Pulse wire connection**

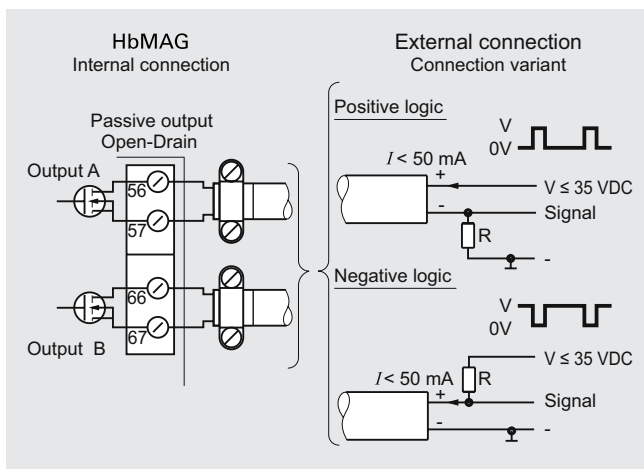

The pulse output can be configured as volume, alarm or call-up. The output can be connected as positive or negative logic.

R = pull up/down is selected in relation to the Vx power supply and with a max. current I of 50 mA.

Use shielded cable to avoid EMC problems. Make sure the shield is correctly mounted under the cable clamp (no pig tail).